

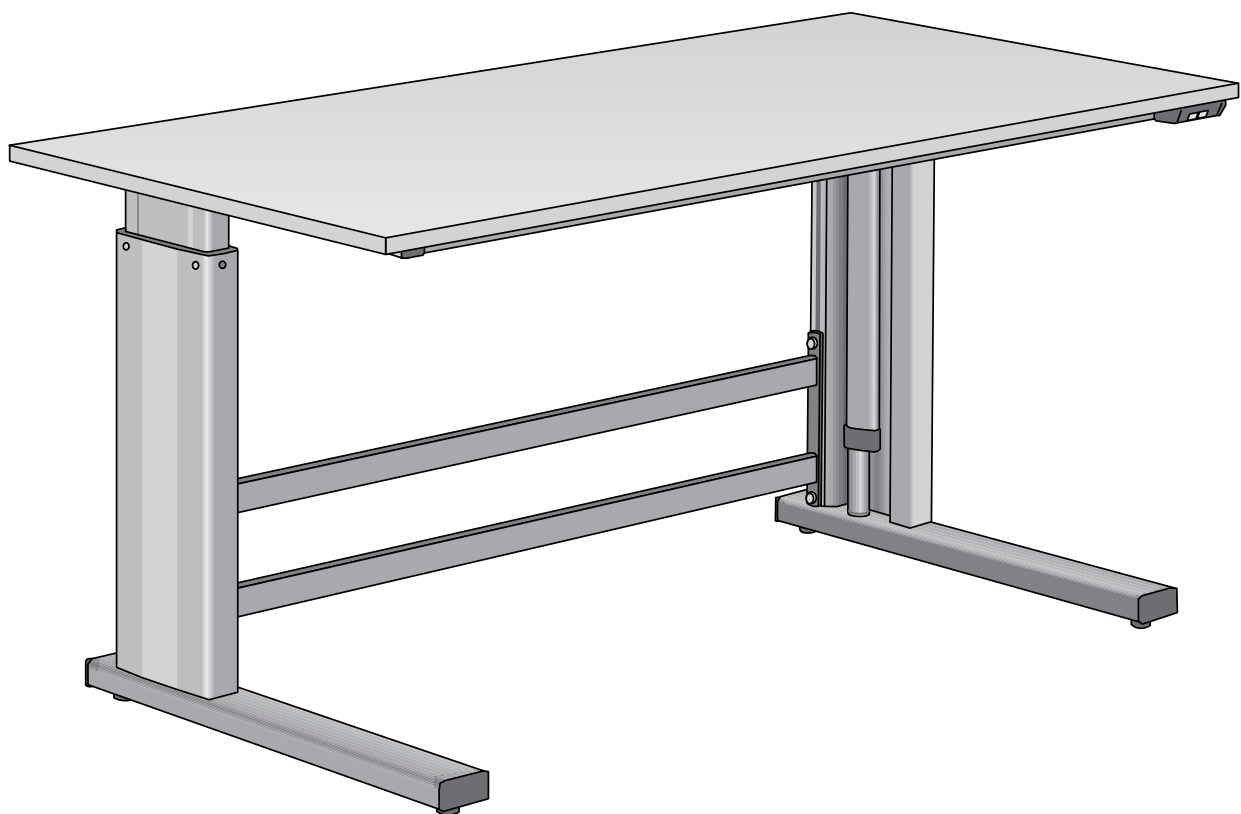

# Flex 375

Worktable – Operating instructions

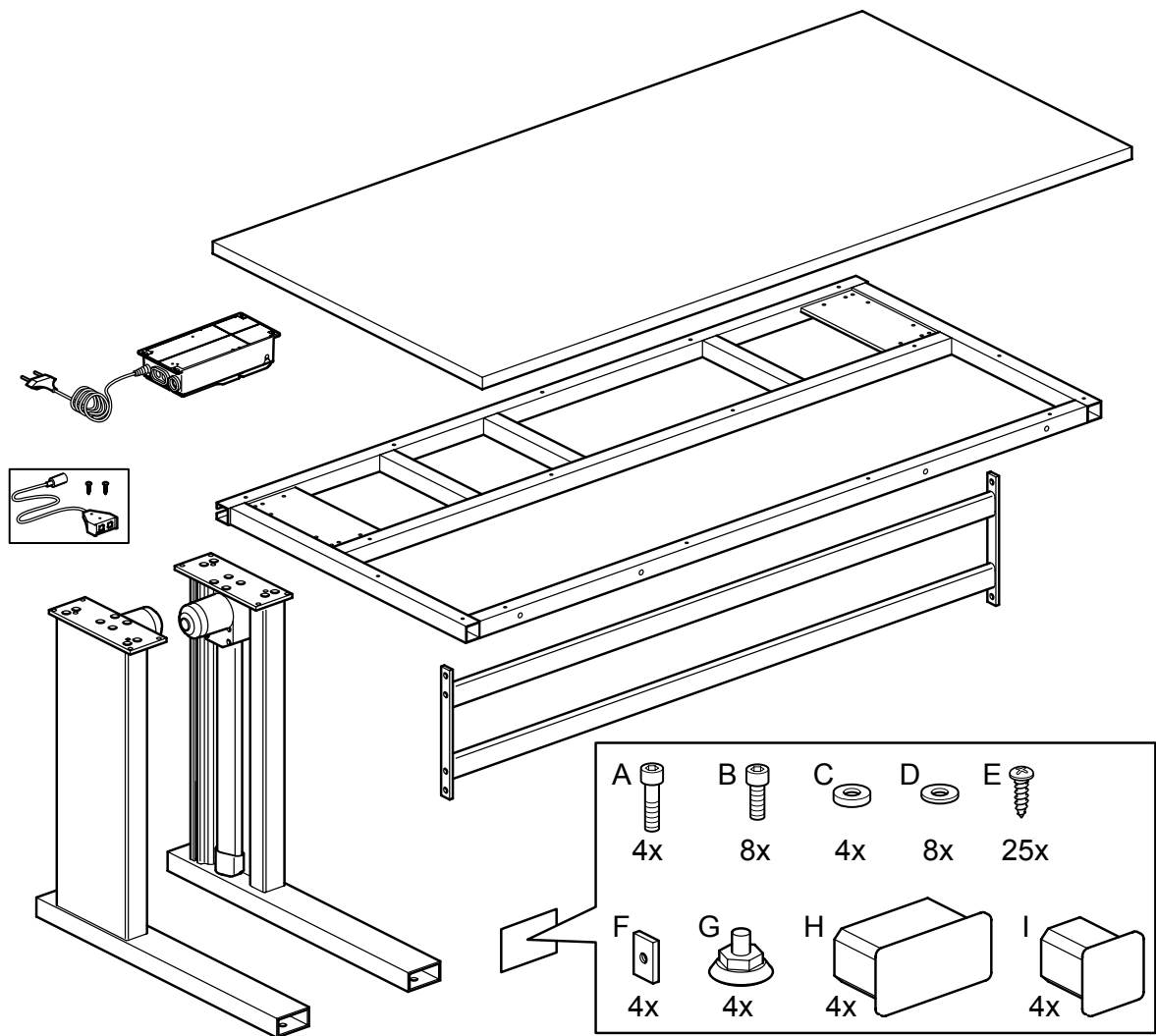



1

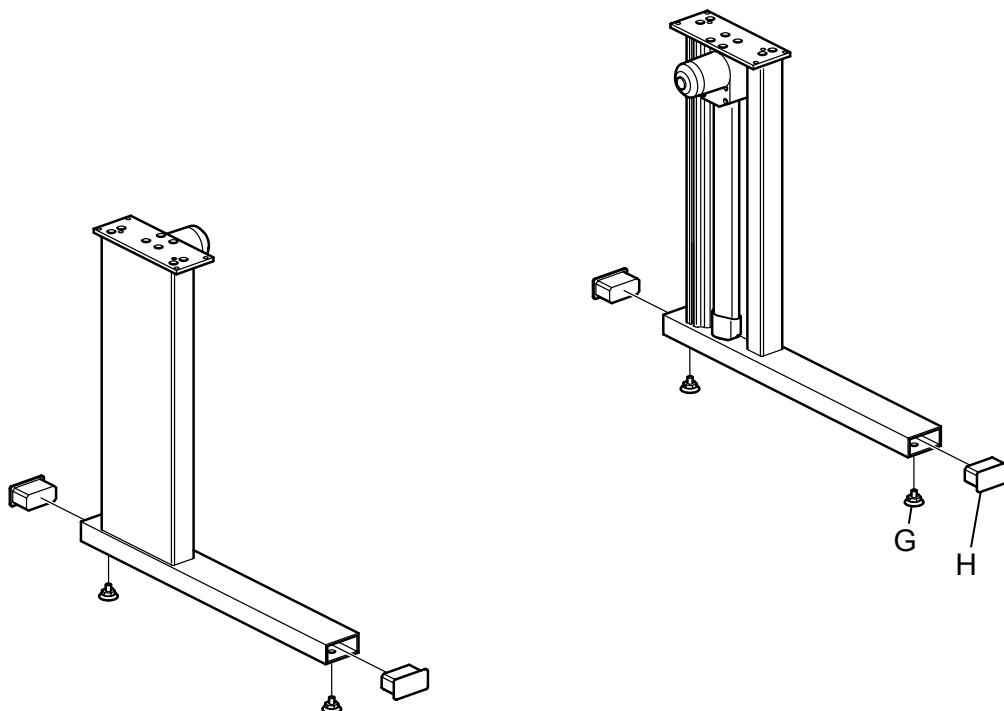

2

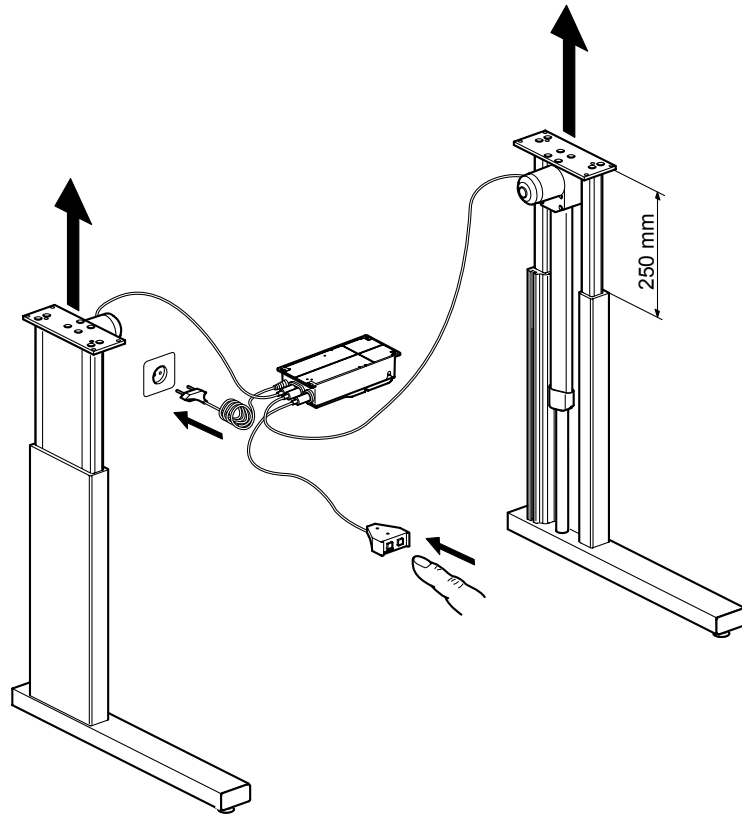

3

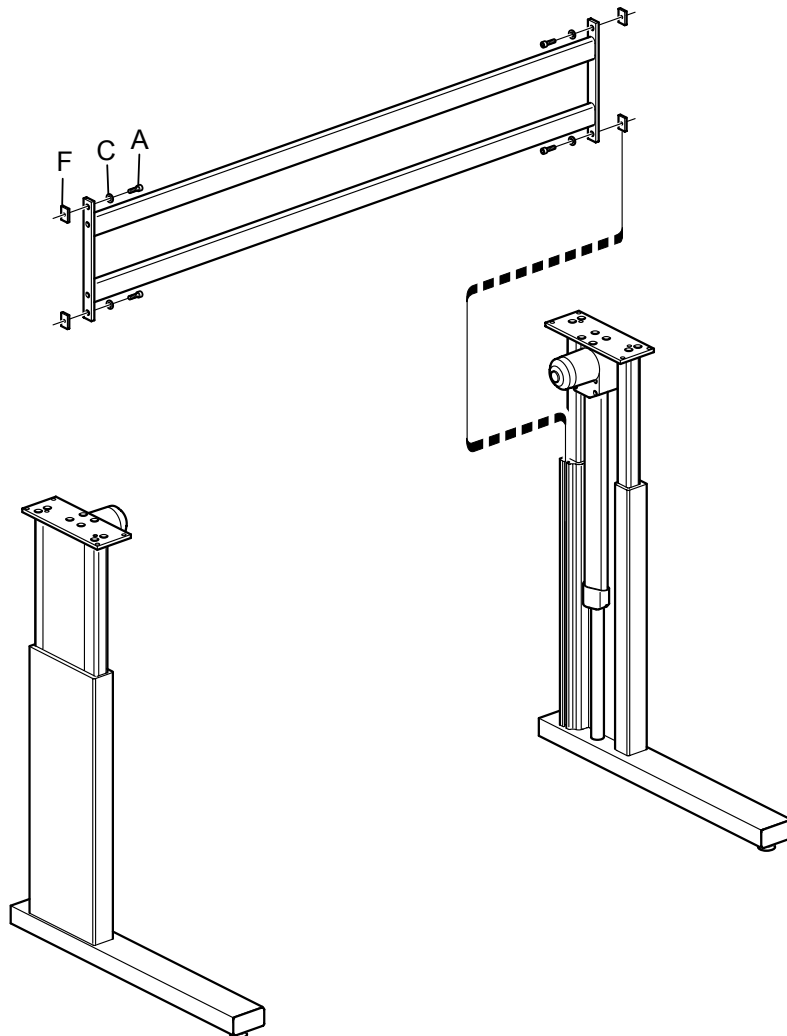

4

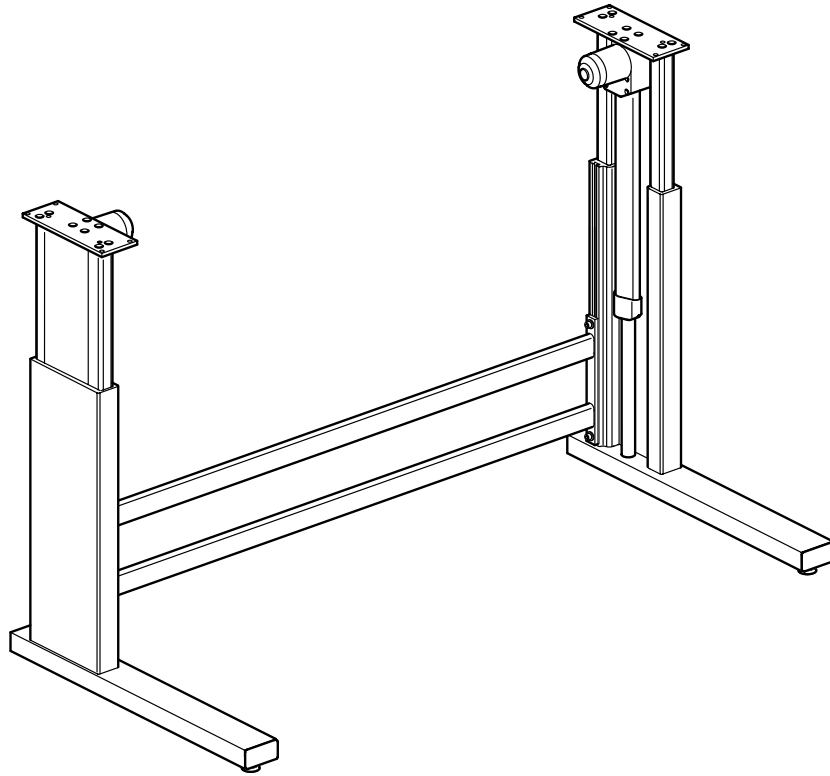

5

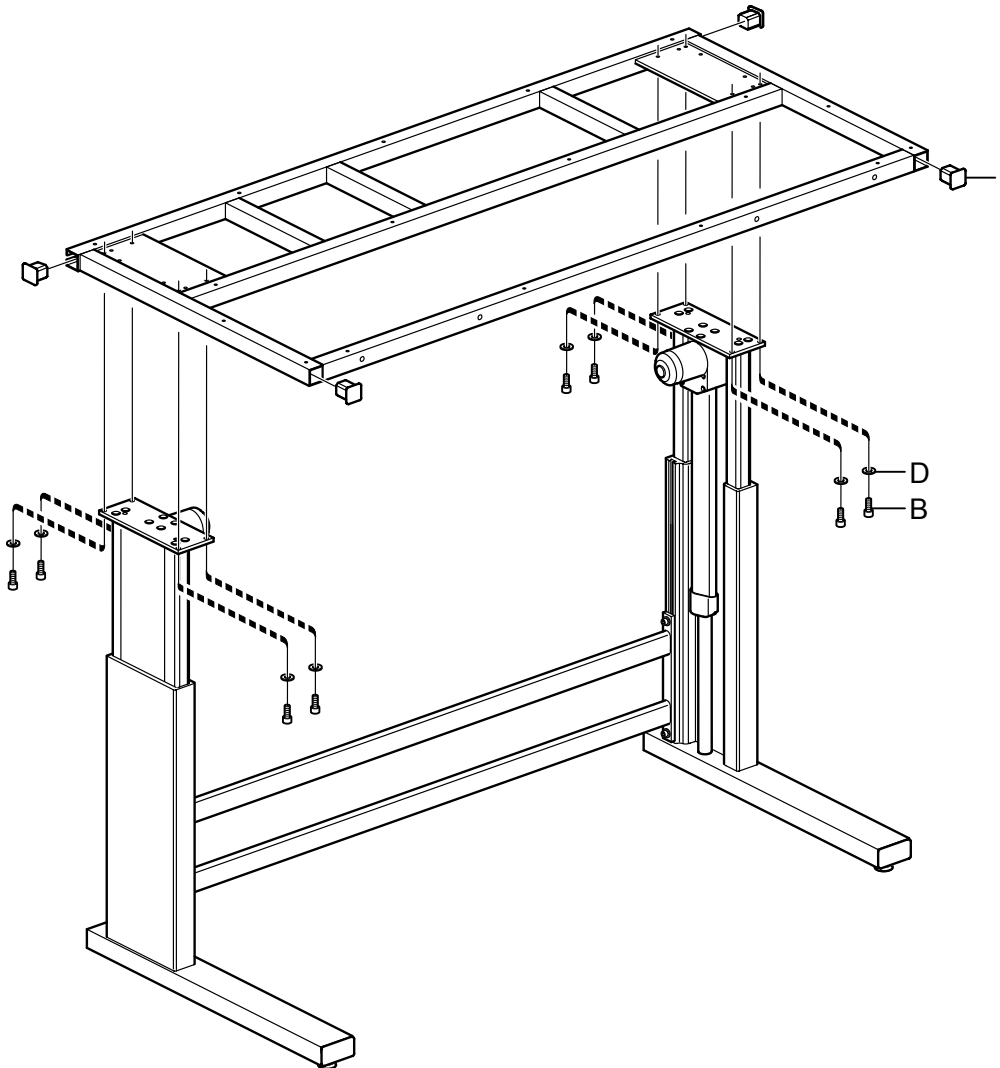

6

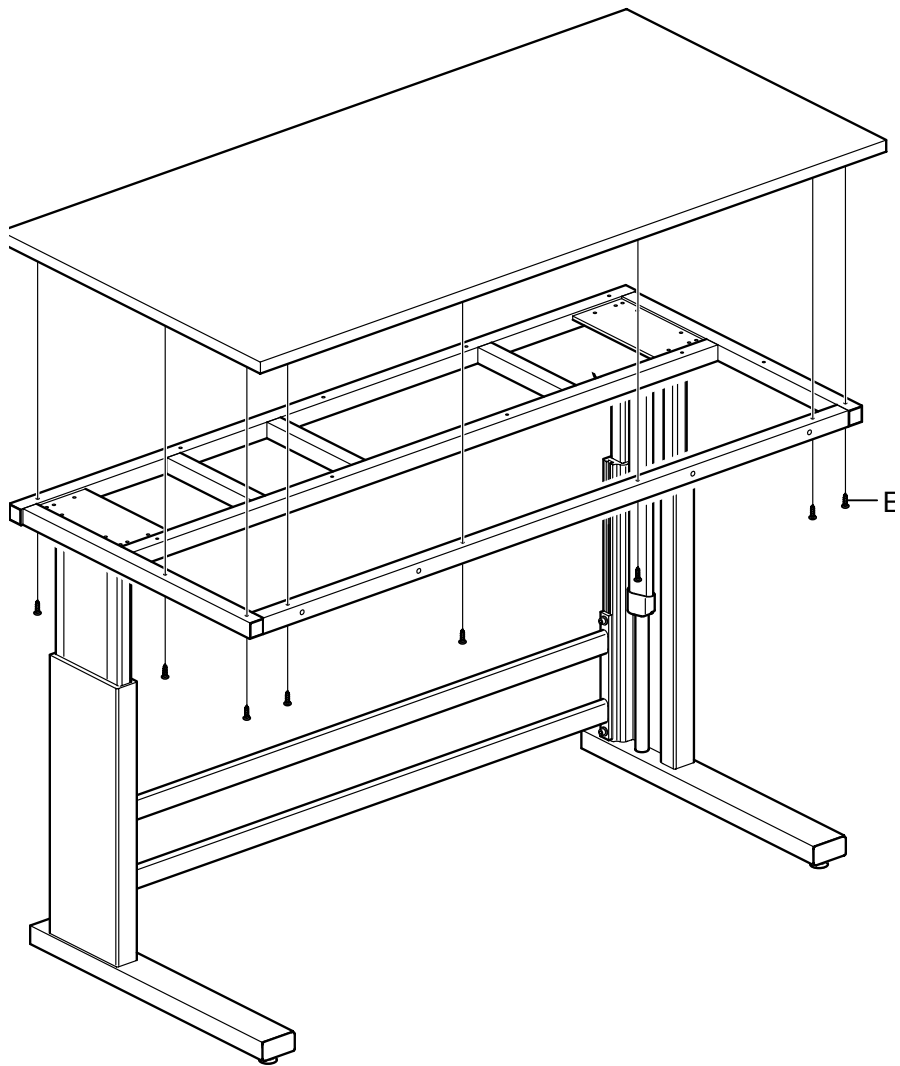

7

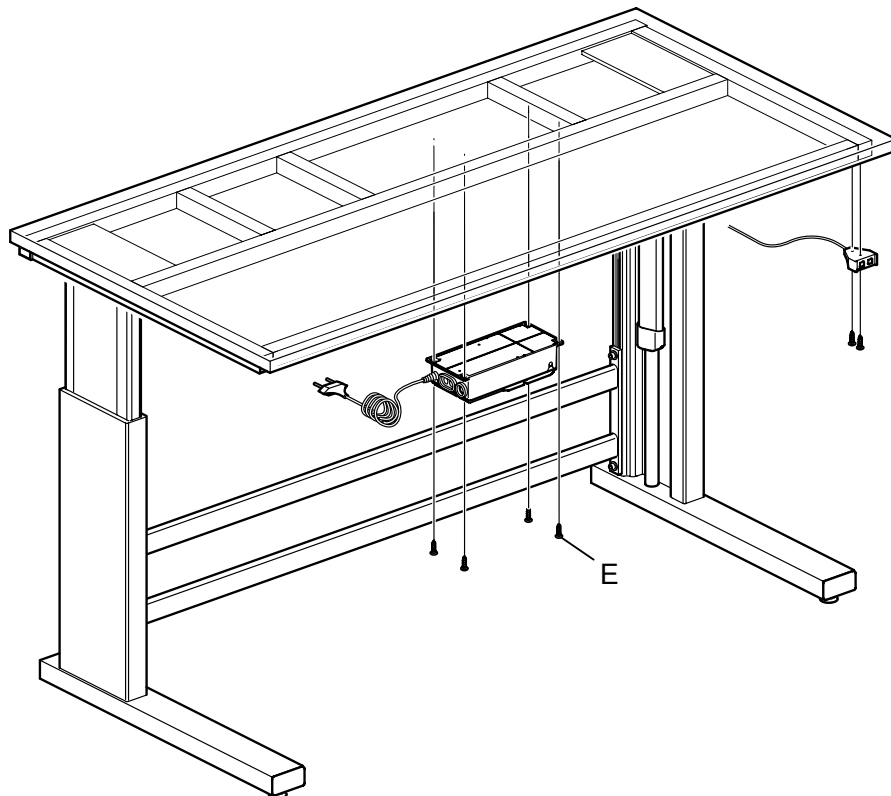

## Installation instructions

- Place the table at least 120 mm from other objects, eg, adjoining tables, equipment, wall mounted shelves, etc.
- Make the top of the table level with the aid of the adjustable feet on the frame.
- Ensure that electric cables are undamaged and that everything is fitted according to the assembly instructions.
- Plug in the power cable of the table, 230 V AC,  $\pm 10\%$ , 50 Hz.
- Press the down button and continue to hold the button pressed until the table has reached to the bottom. Release the button and press it again. After approximately 5 seconds, you will hear a clicking sound from the control unit. The resetting will then be ready and the product can be put into use. It may be necessary to repeat the procedure later to ensure that parallel operation is satisfactory.

If the table is to be placed in series then additional safety devices must be fitted in accordance with instructions by Gigant.

When moving the table, never lift it by the top of the table because the frame is too heavy.

## Description

The table is made for indoor use in an industrial or office environment and for 10% intermittent lifting operation, ie, maximum 6 minutes per hour (maximum 2 minutes continuous operation).

## Configuration

The figure shows the main parts of the table.

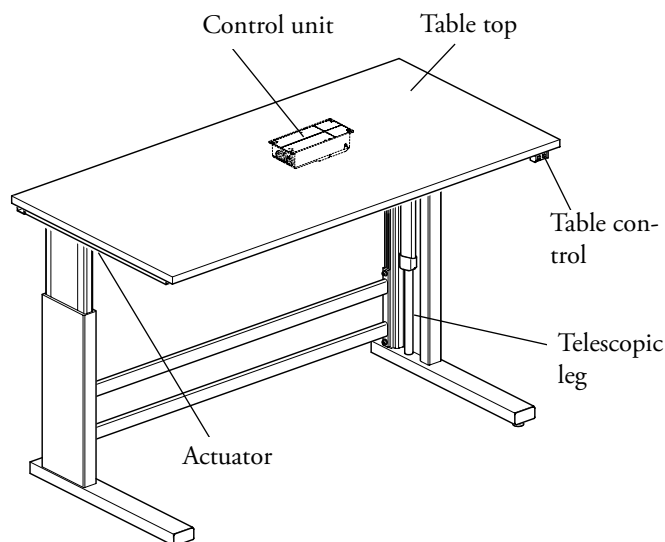

## Function

Lifting is achieved by two electric motors that are interconnected with a control unit. Glide plates fitted in each telescopic leg ensure smooth and even lifting action. The sound level of the table is lower than 70 dB(A).

## Accessories

Accessories that are approved by Gigant for tables Gigant Flex 375 include the following:

- Hand control with flexible cable.
- Foot pedal.
- Supplementary frame.
- Manual tilting of table top.
- Motor powered tilting of table top.
- Drawer and drawer suspension.

## Operating instruction

Raising and lowering the table

- Ensure that the table top, and anything placed on the table, has clearance in relation to surrounding objects.
- Press the table control to give the desired action. (The motor runs so long as the table control is actuated.)

### Warning!

Observe the danger of crushing between the table top or frame and adjoining equipment when raising and lowering.

The danger of tipping must be considered if load protrudes beyond the extent of the frame.

For tables with a top that can be tilted:

### Warning!

Observe the danger of crushing if the table is fitted with an adjustable tilting top.

Caution. The top may not be tilted when loose objects are on the table since this could otherwise result in personal injury.

## Maintenance

A detergent with a pH level between 6 and 8 should be used for cleaning the frame.

Inspect terminals, cables and cable clamps at regular intervals.

The power cable must be unplugged before attempting any service work on the table.

All moving parts are lubricated at the factory and are therefore free from maintenance.



[www.gigant.co.uk](http://www.gigant.co.uk)